

WEAVE

Systeme de fibres optiques pour le spectrographe multi-objets WEAVE

Prototypage Fibweave: action financée par la région Ile-de-France



LE PROJET WEAVE

- Le projet WEAVE et le WHT
- Le projet WEAVE et son contexte scientifique
- Les fibres optiques du projet
- L'organisation du projet
- FIBWEAVE: prototypage des fibres optiques du MOS
- Les tests
- Bibliographie
- Conclusion

Le projet WEAVE et le WHT

Positionneur de fibres
Correcteur de champ
Câbles de fibres optiques
Spectrographe

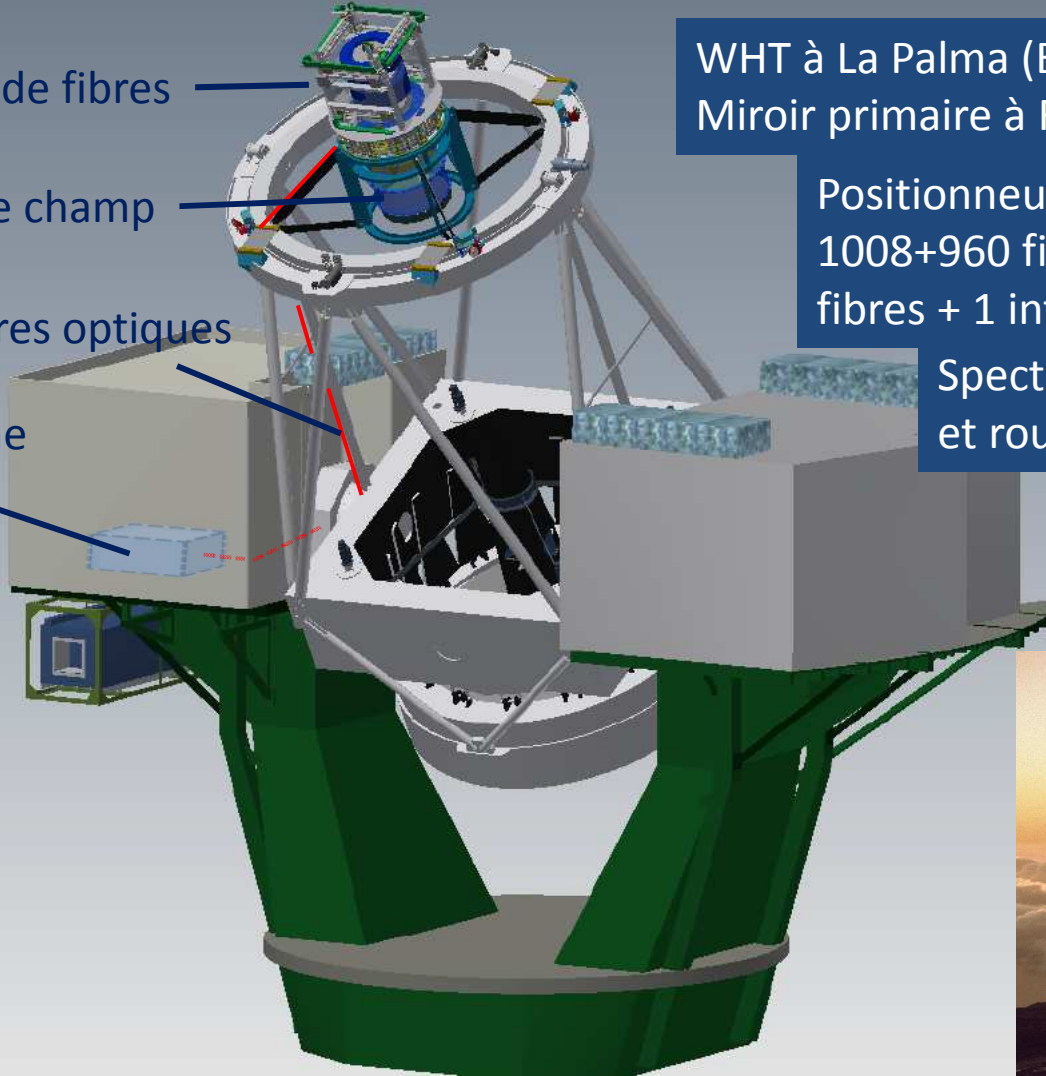

WHT à La Palma (ESP) de 4.2m de diamètre
Miroir primaire à F/2.77 avec un correcteur 2°

Positionneur de fibres avec 2 plateaux
1008+960 fibres (MOS) + 20 mIFU de 37
fibres + 1 intégral de champ à 600 fibres

Spectrographe à 2 voies (bleue
et rouge) alimenté par 1000 fibres

2 VPH optimisés pour
les résolutions :
R=5000 et 20000



Le projet WEAVE et son contexte scientifique (1)

- Etude de la dynamique et de la composition chimique des étoiles de la Galaxie (spectroscopie sol: accompagnement de GAIA).
- Nature de la matière sombre et de l'énergie sombre? Formation et évolution des galaxies (complément nécessaire de LOFAR, APERITIF et CLUSTER)

Le projet WEAVE et son contexte scientifique (2)

A résolution $R=5000$ WEAVE fournira des vitesses radiales pour les étoiles trop faibles pour Gaia-RVS

A résolution $R=20000$ WEAVE fournira des vitesses radiales avec une erreur < 1 km/s et des abondances chimiques détaillées (précision < 0.1 dex) pour plusieurs éléments.

Courtesy Vanessa Hill (OCA)

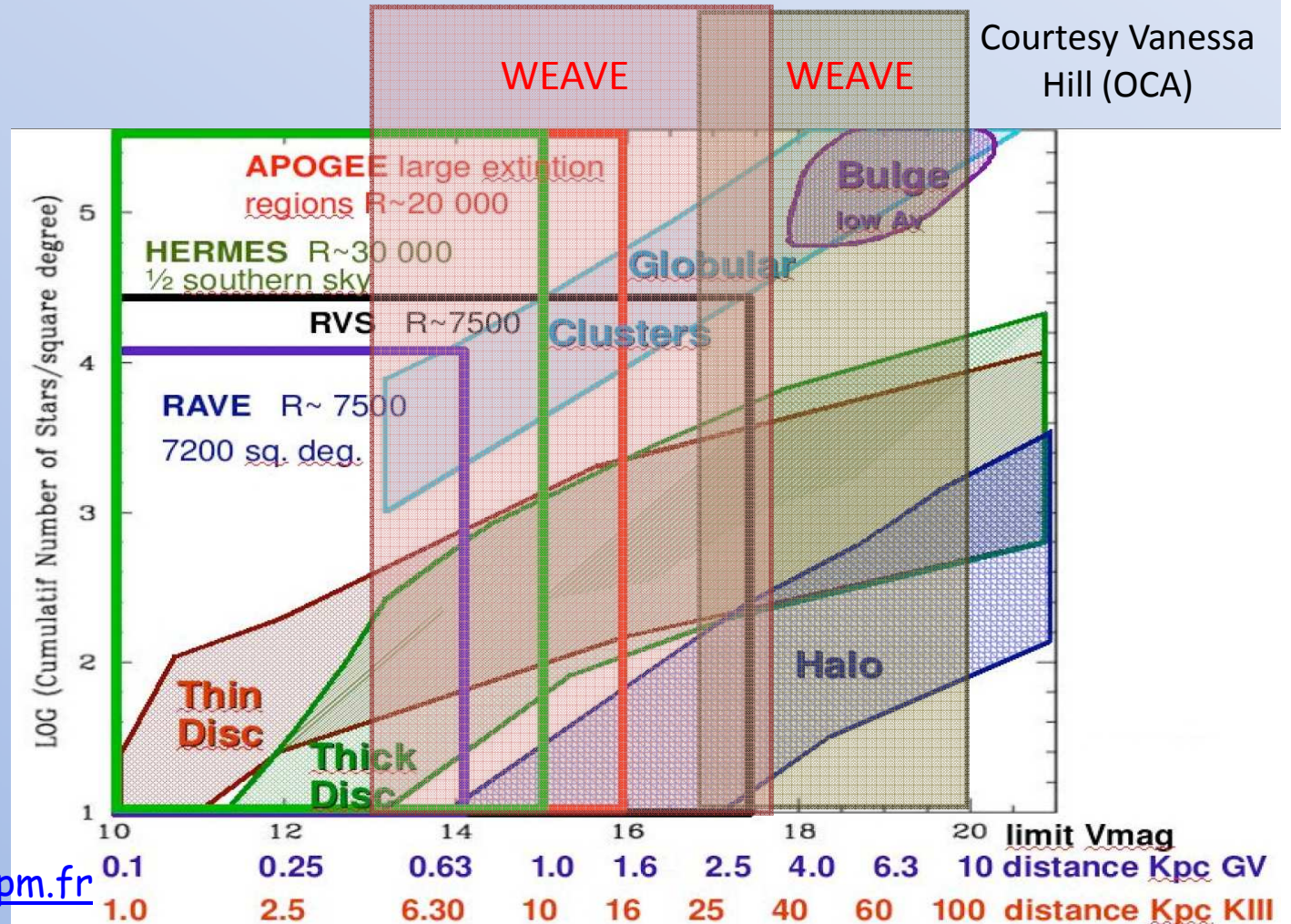

Contact:

Piercarlo.bonifacio@obspm.fr

Co-PI du projet WEAVE

Colloque DIM ACAV - 17/11/2014

Frederic.sayede@obspm.fr

Les fibres optiques du projet WEAVE (1)

Le correcteur de champ et le positionneur

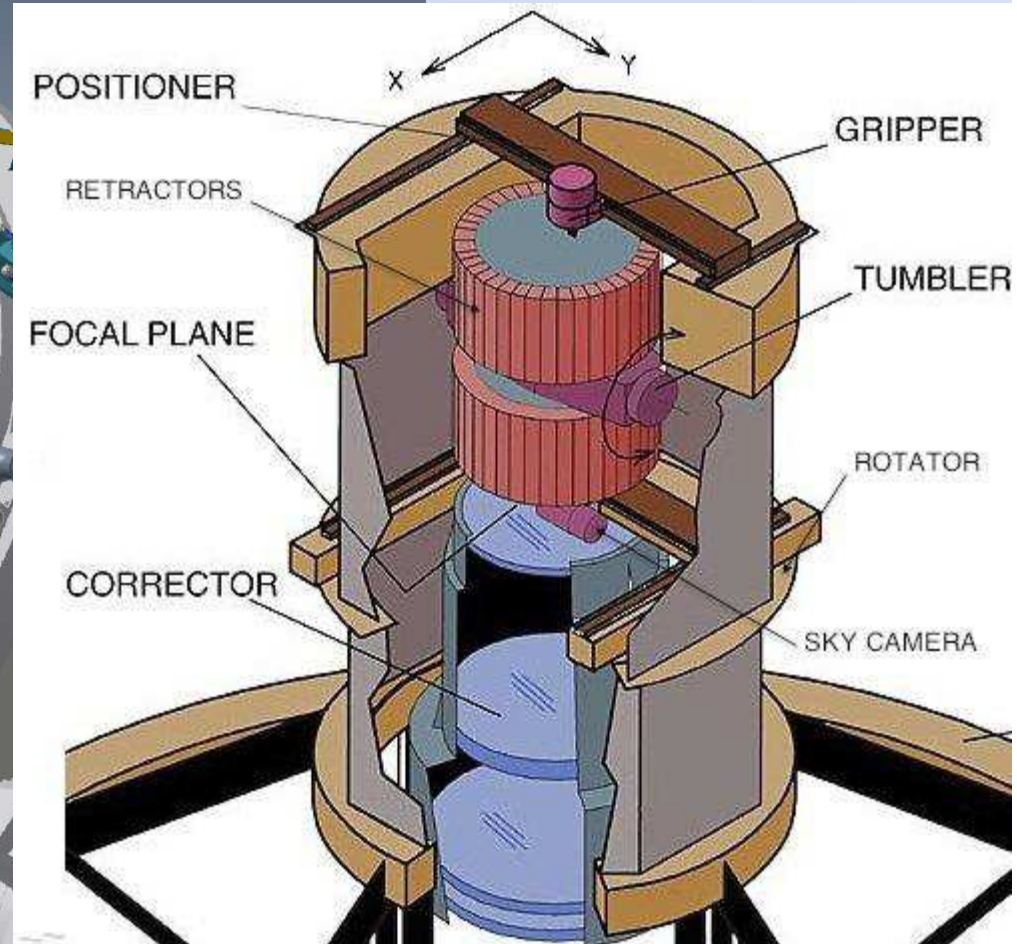
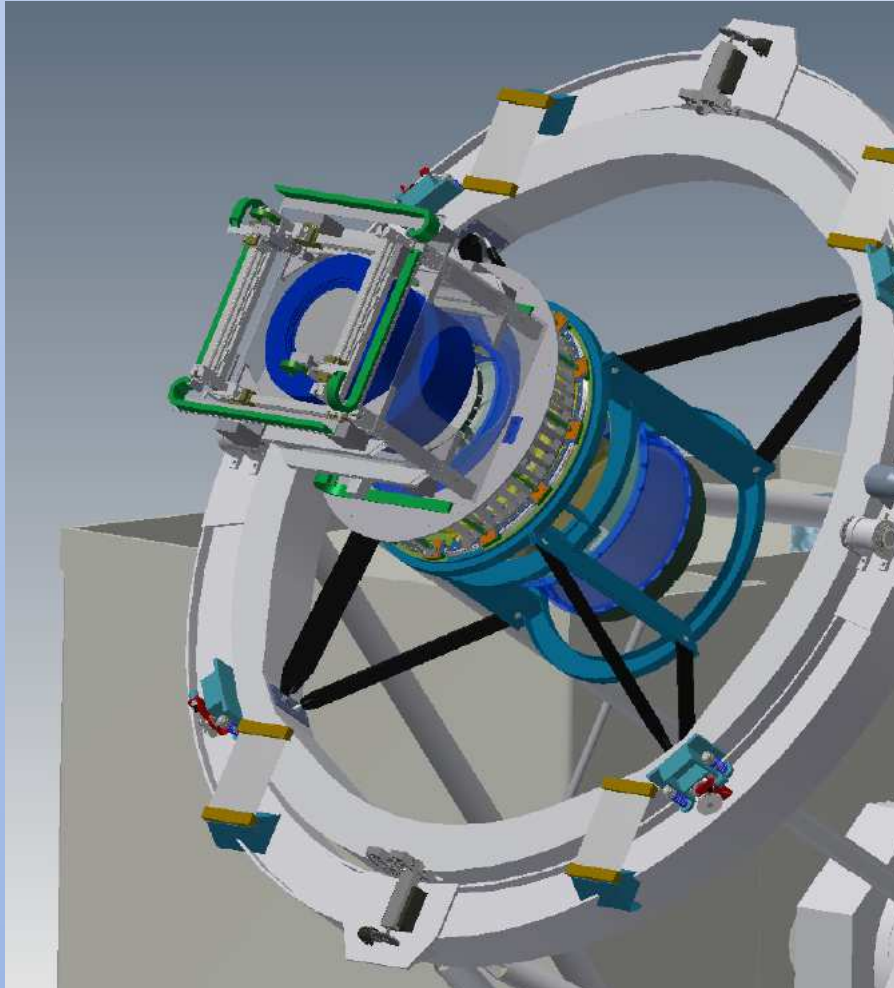

Les fibres optiques du projet WEAVE (2)

Le correcteur de champ et le positionneur

1000 fibres sur un diamètre de 400mm (2°)

Robot Positionneur de fibres optiques 2dF (équivalent au positionneur de Weave)

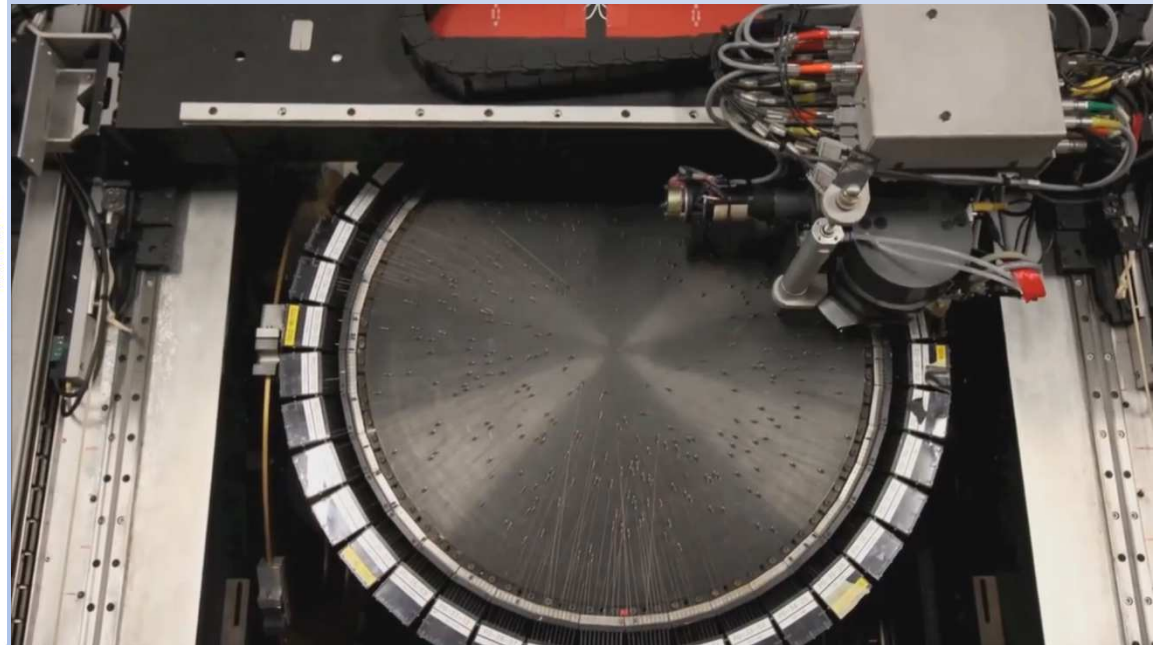
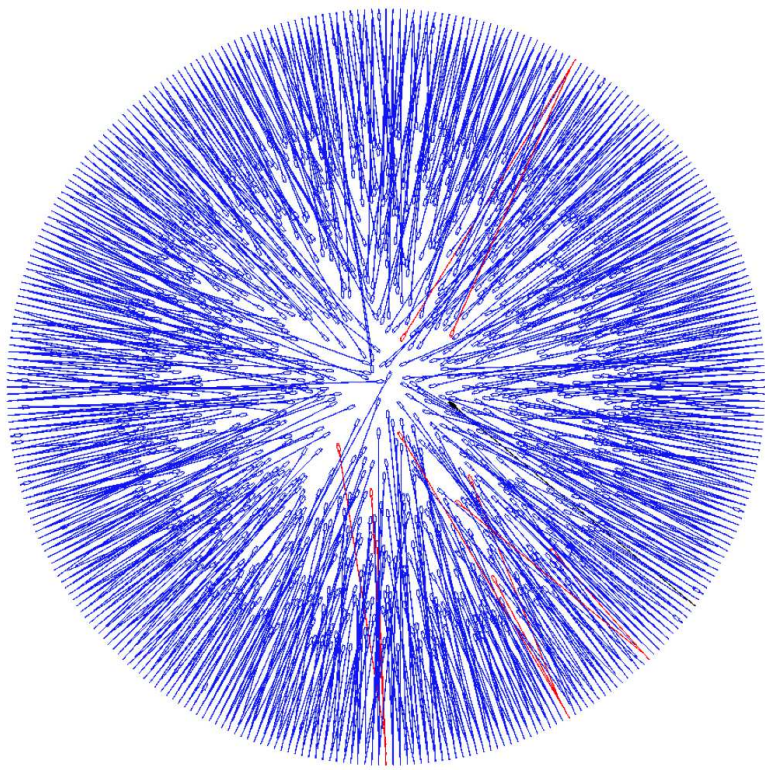

Les fibres optiques du projet WEAVE (3)

MOS Multi Object Spectrograph



1,2 arcsec

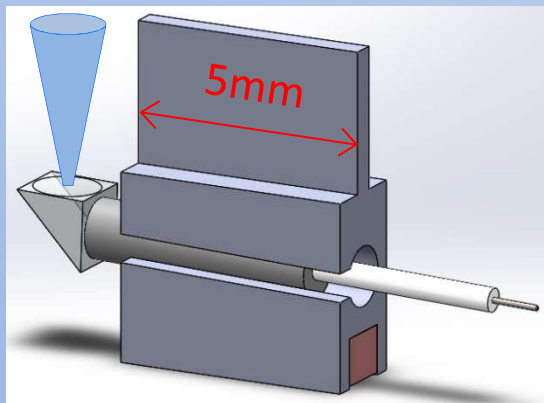

mIFU mini Integral Field Unit

1,2 arcsec x 37

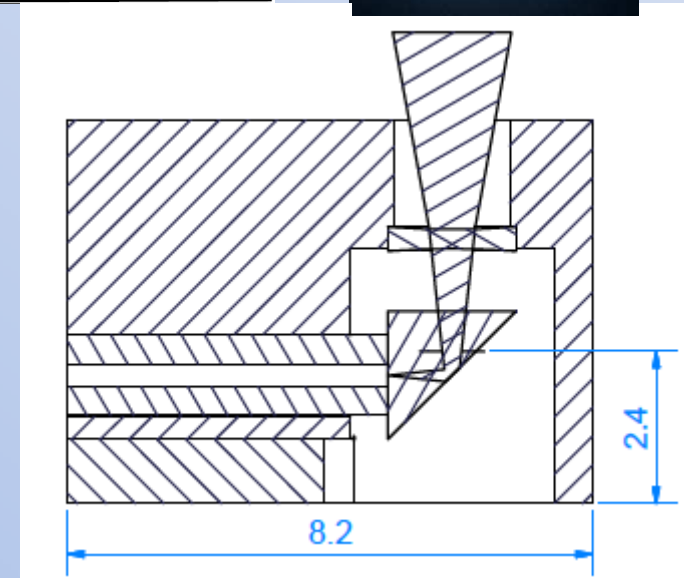
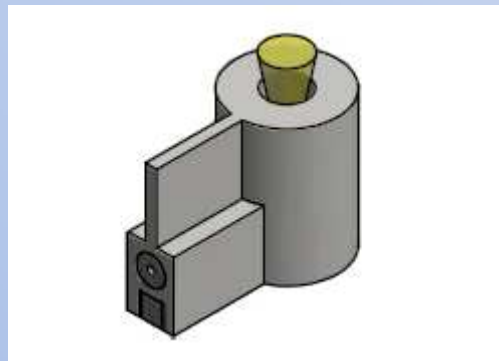
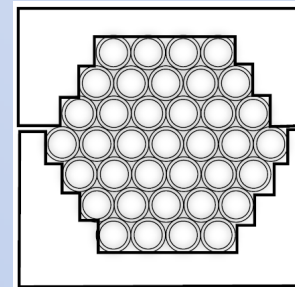

Les fibres optiques du projet WEAVE (4)

LIFU: Large Integral Field Unit

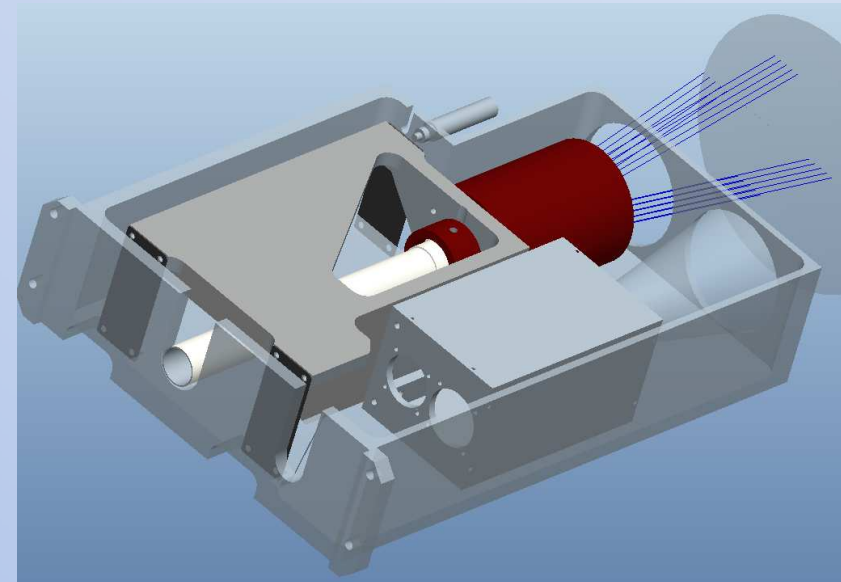
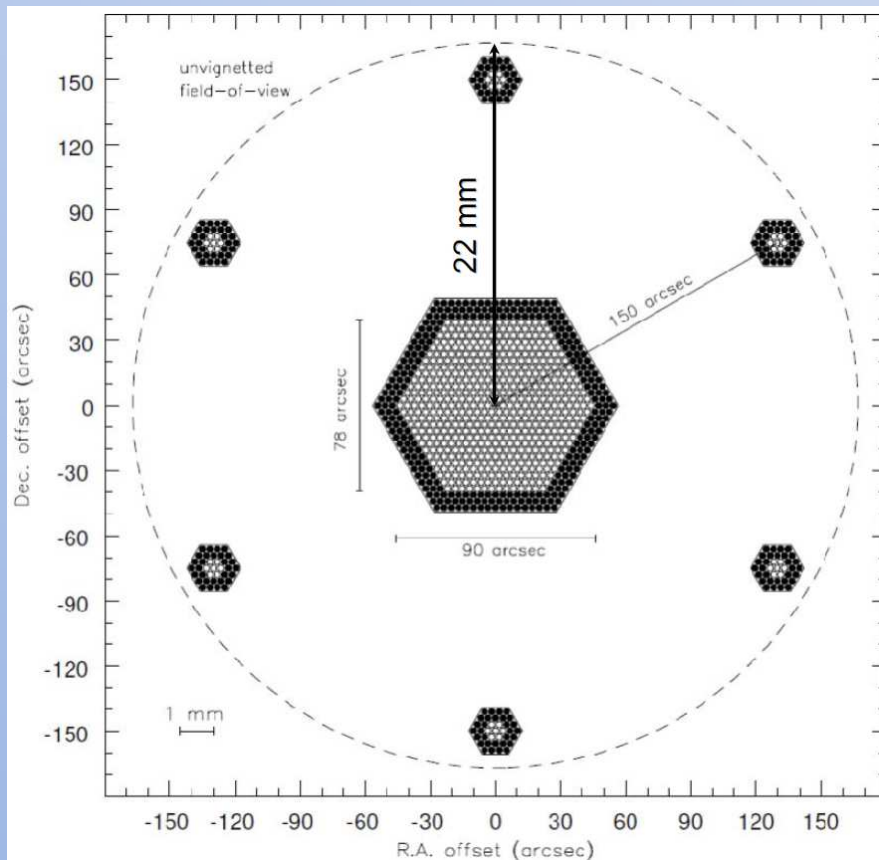

Les fibres optiques du projet WEAVE (5)

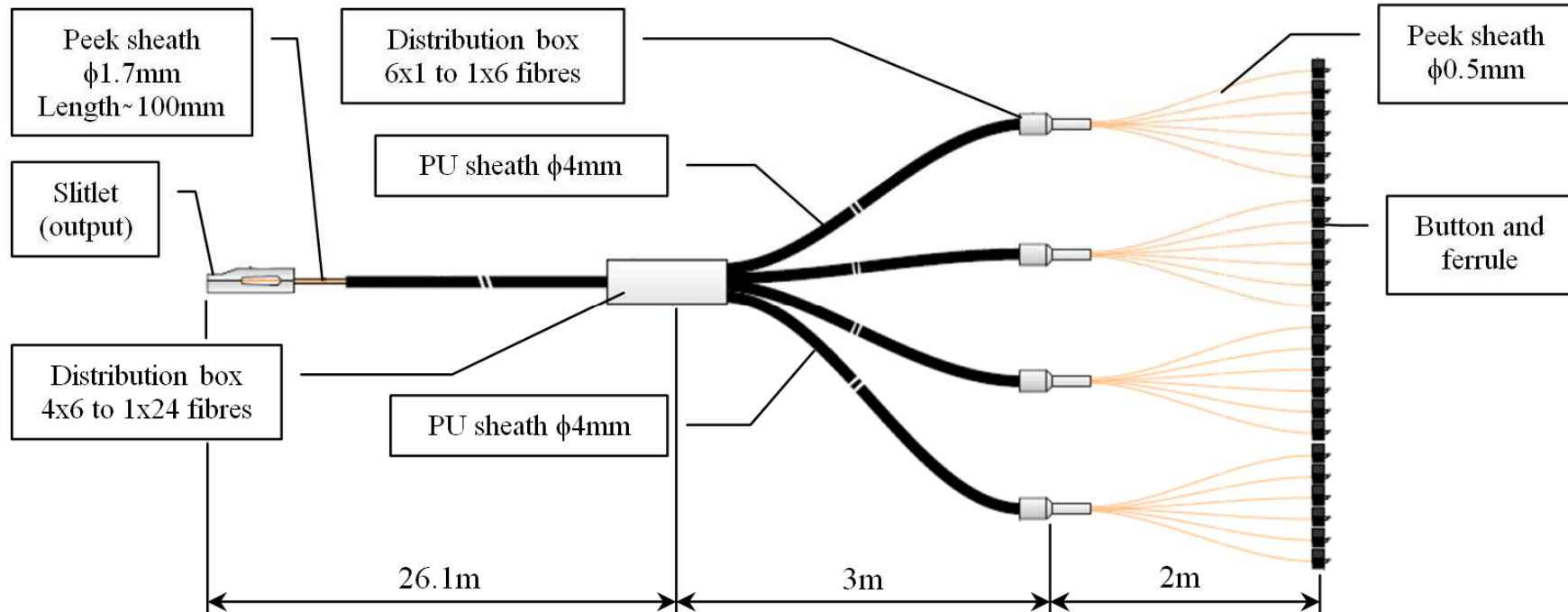
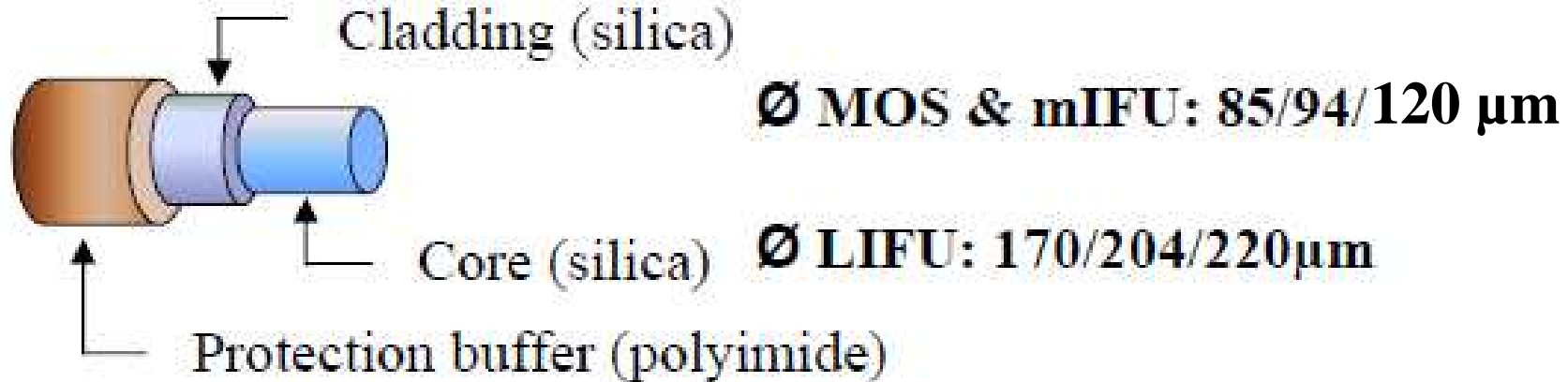

Les fibres optiques du projet WEAVE (6)

Fente d'entrée du spectrographe

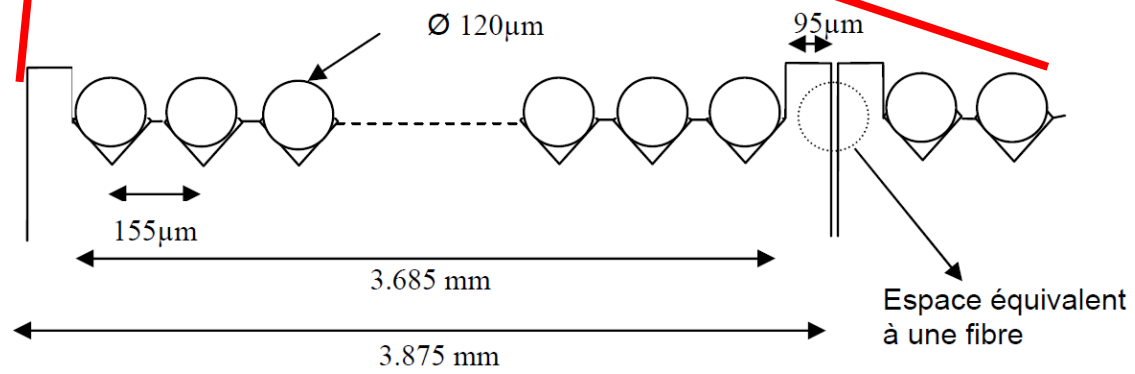
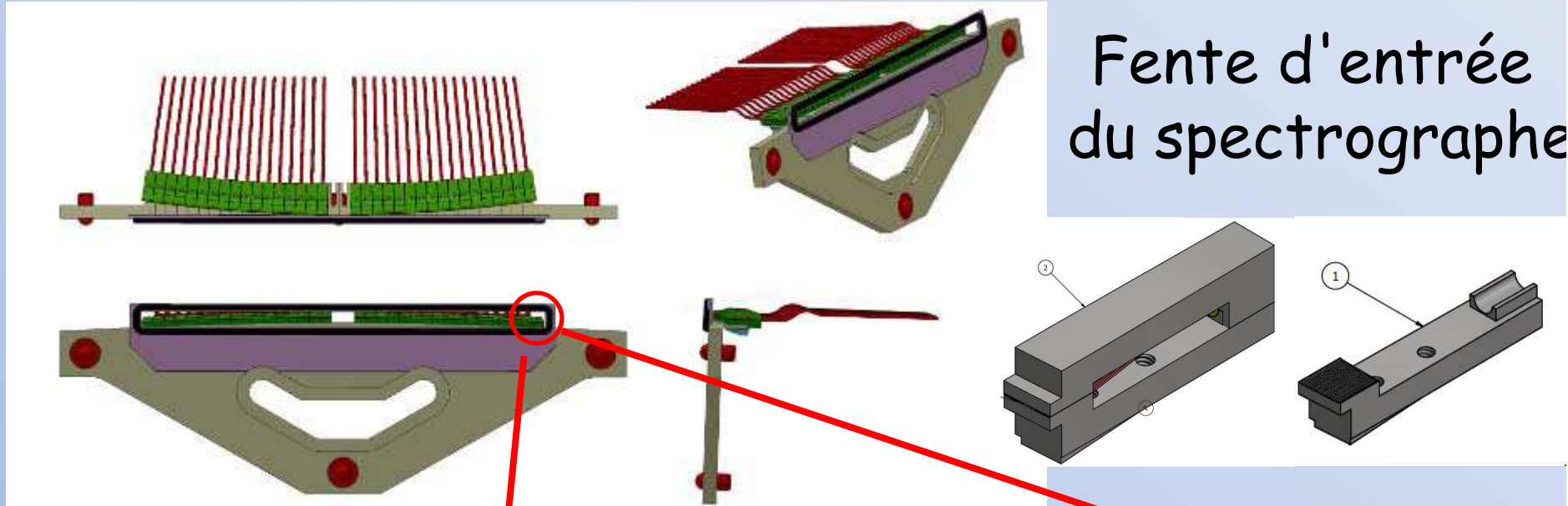

L'organisation du projet WEAVE (1)

Institute	Responsability
STFC - RAL	PI, System Engineer, Software
NOVA - Univ. of Groningen	Spectrograph, Project Scientist
ING	Corrector, Telescope, Project Manager, Instrument Scientist, Software
LJMU	Detector systems
Univ. of Oxford	Fibre positionner
GEPI	Fibre system, Deputy manager, Co-PI
IAC	Data Analysis Software, Co-PI
INAF	Archive, VPH gratings, Spectro. control Software



L'organisation du projet WEAVE (2)

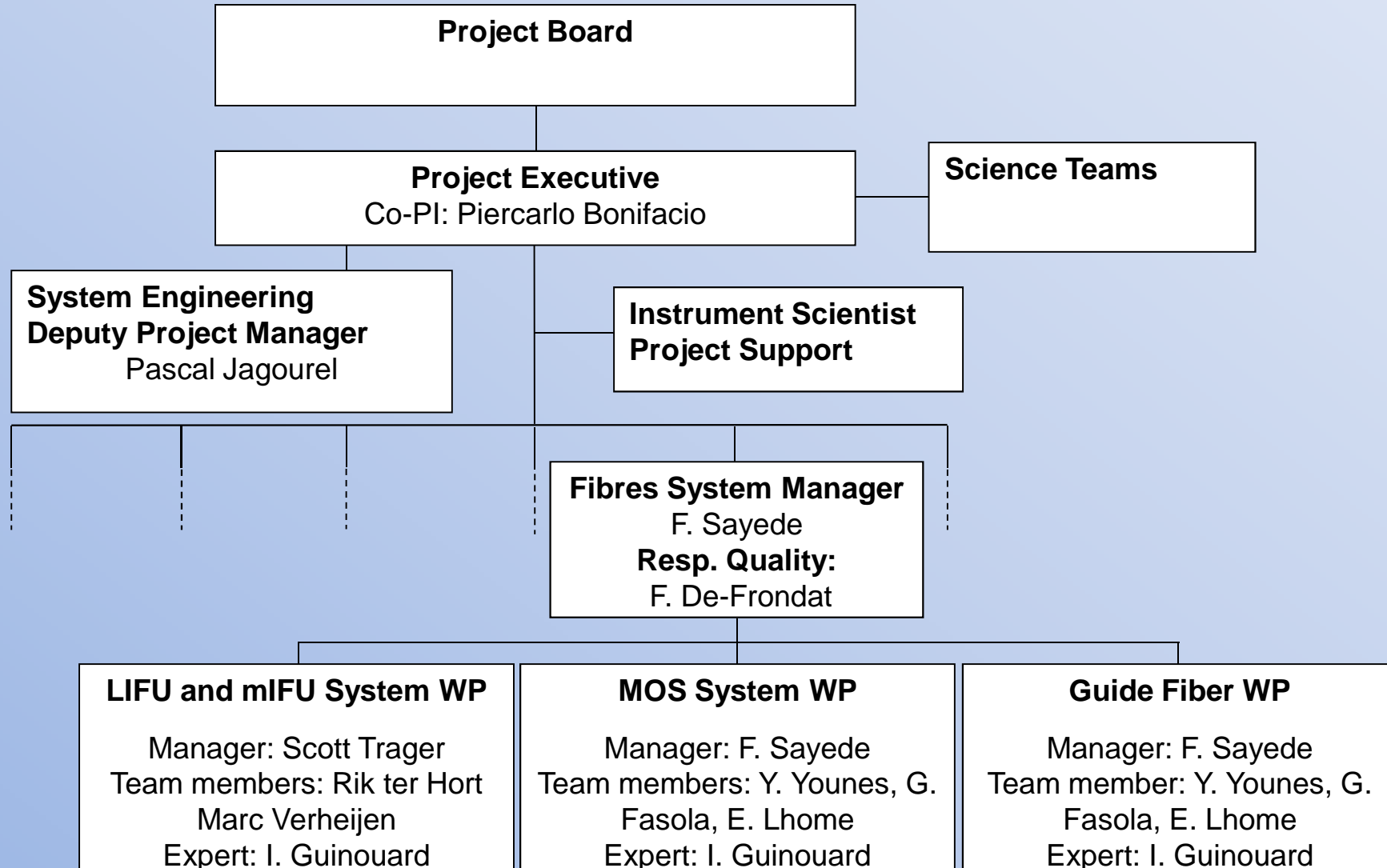

L'organisation du projet WEAVE (3)

Prototypage MOS / Banc de test : fin 2014
(Automatisation du banc de test: avril 2015)

Etude de phase C « Fibre System »:
FDR en Mars 2015 (AC)

Définition (Opt:avril13 Gén: avril15)

MAIT (Janv 2017)

Intégration télescope

Opération (mi-2017)

FibWeave: prototypage des fibres optiques du MOS

Contrat signé en juin 2013 avec SEDI
=> Pré-industrialisation des torons de fibres

- Réalisation de 10+1 torons de fibres MOS avec les boutons, les câbles et les fentes de sortie
- Réalisation des bancs de tests
- Tests des torons

Les tests (1)

ID	Description	Performance requirement	Type of verification with low automation	Type of verification with full automation
1	The FIB shall transmit light from science objects on field plate to the spectrograph.	-	Systemic Test	Systemic Test
2	Average throughput (400-600nm)	> 70%	Statistical Test*	Systemic Test*
2	Average throughput (600-950nm)	> 75%	Statistical Test*	Systemic Test*
3	Output F-ratio	3.1 ± TBD	Statistical Test	Systemic Test
4	Fibre aperture on sky	1.3'' ± 5%	Statistical Test	Systemic Test
5	Angular Position of the prism axis	± 2° with theoretical position	Statistical Test (at list one per angle value)	Systemic Test
6	Spacing of adjacent fibre on a slitlet	116±TBDµm	Statistical Test	Systemic Test
7	Relative Angular position of the fibres at the output (position of the pupil on the grating)	TBD	Statistical Test	Systemic Test

*One absolute measure and relative measures

Les tests (3)

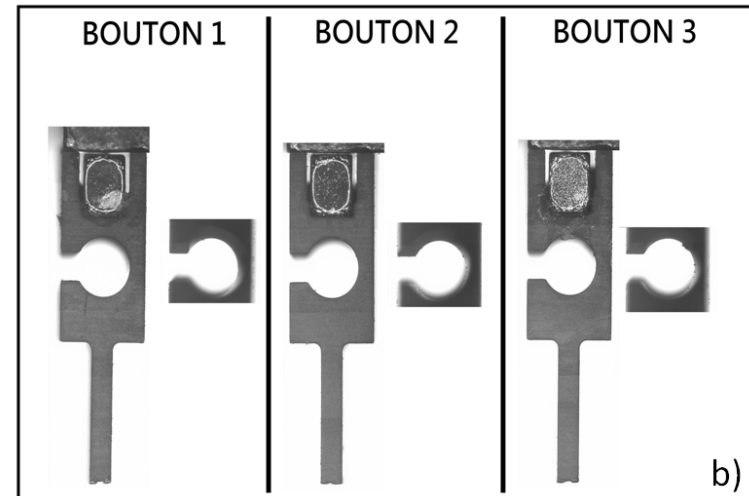
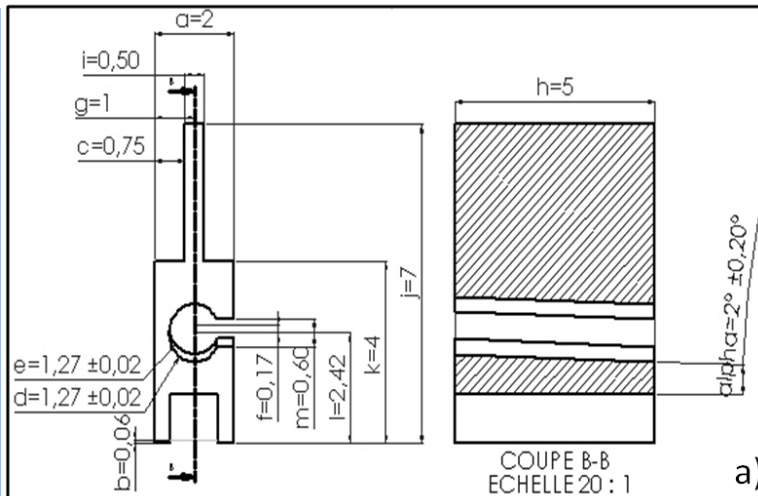
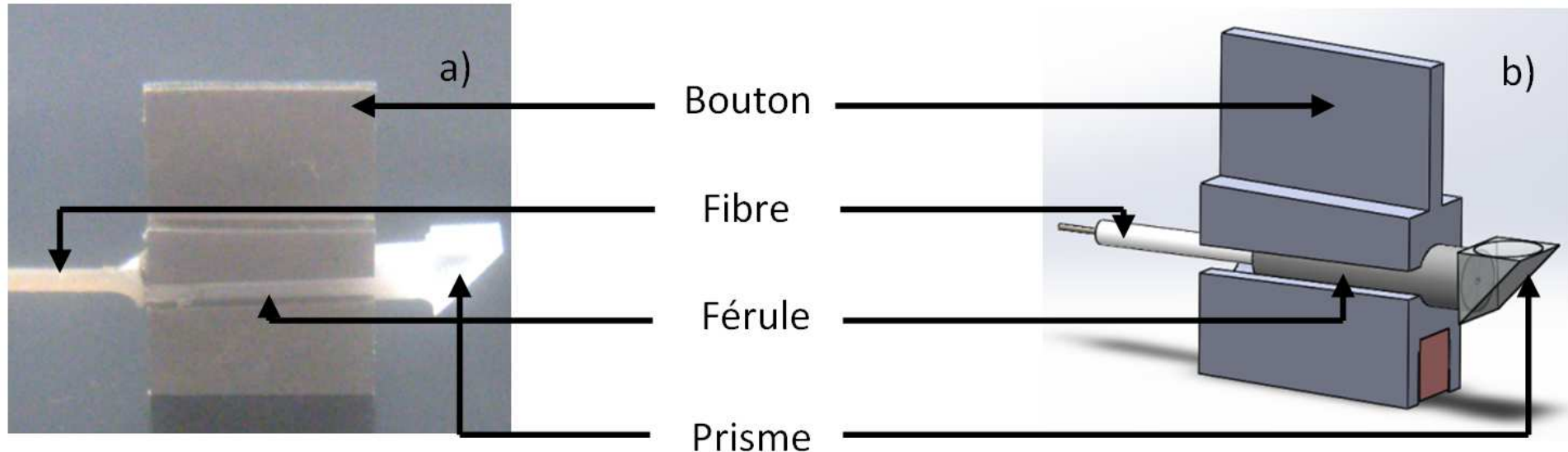

Les tests (4)

Le banc de test

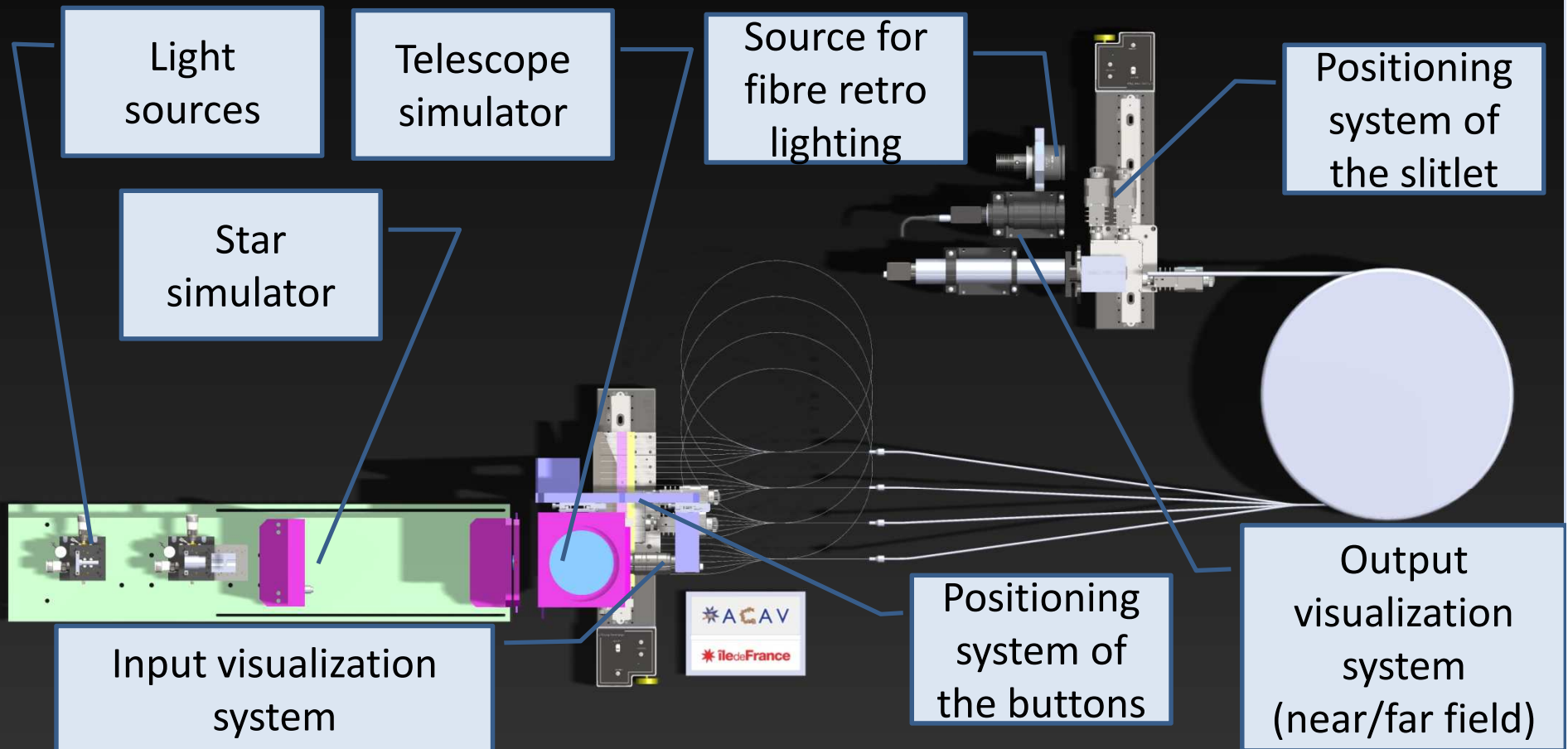

Les tests (5)

Dernières publications

- [1] Dalton G. et al, "WEAVE: the next generation fibre spectroscopy facility for the William Herschel telescope: project overview and update on the final design stage", Proc. SPIE 9147-20 (2014)
- [2] Dalton G. et al, "WEAVE: the next generation fibre spectroscopy facility for the William Herschel telescope", Proc. SPIE 8446-23 (2012)
- [3] Guinouard I., Bonifacio P., Trager S. C., Verheijen M. A. W., Lewis I., Dalton G., "Development of the single fibres and IFUs of WEAVE", Proc. SPIE 8450-127 (2012)
- [4] Abrams D. C. et al, "The mechanical design for the WEAVE prime focus corrector system", Proc. SPIE 9147-93 (2014)
- [5] Lewis I. J. et al, "The fibre positioning system concept for WEAVE at the William Herschel telescope", Proc. SPIE 9147-117 (2014)
- [6] Rogers K. et al, "The design of the WEAVE spectrograph", Proc. SPIE 9147-242 (2014)
- [7] Agocs T. et al, "Final optical design for the WEAVE two-degree prime focus corrector", Proc. SPIE 9147-266 (2014)
- [8] Terret D. L. et al, "Fibre positioning algorithms for the WEAVE spectrograph", Proc. SPIE 9152-23 (2014)
- [9] Sayede et al, "WEAVE MOS Fibre Bundle Test Plan", Proc. SPIE 9151-227 (2014)

Conclusion

- Cette action financée par la région Ile-de-France permet de mettre en place un processus d'industrialisation de torons de fibres optiques ainsi que les systèmes de test « automatisés » associés.
- Ce développement placera le GEPI et l'industrie francilienne dans une position privilégiée pour la réalisation d'autres instruments fibrés (ex: MOONS pour le VLT de l'ESO, instrument E-ELT...)
- Le système "fibres" est le point d'entrée pour la communauté francilienne et française au projet ambitieux WEAVE.



Merci pour votre
attention...